

## REAGENT STORAGE CABINET – RC-1215

MACHLAB<sup>®</sup> Reagent storage cabinets have distinctive features that are designed to provide convenient storage for your chemical reagents and meet international laboratory safety standards.

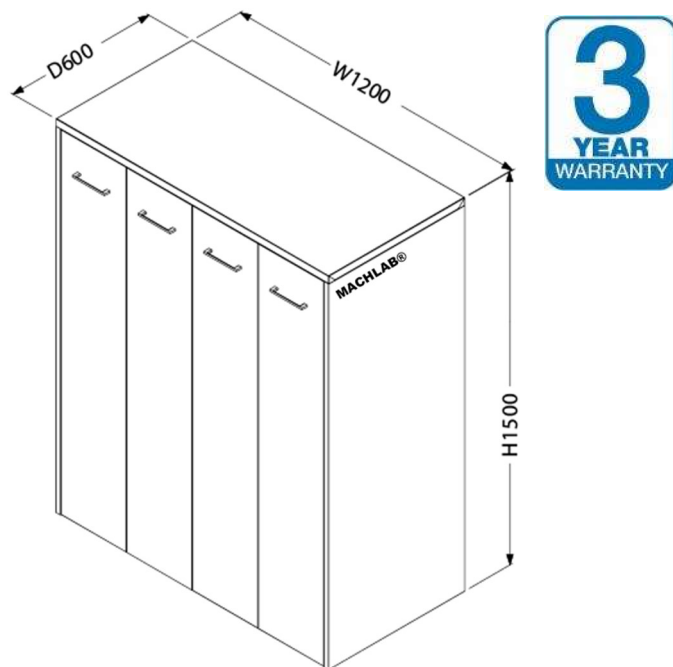

### FEATURES

- Durable **lab-grade construction**
- **100 microns** powder coating finish
- **Corrosion resistance** certified
- **Fail-safe heavy-duty** sliding mechanism
- **Exhaust ventilation collar** add-on available

### SPECIFICATIONS

- **Certified quality** (ISO2178, ISO2813, ISO2409, ASTM 117, ASTM D3363)
- Manufactured of **heavy-duty steel** (22-gauge, electro-galvanised)
- Stainless steel/Aluminium alloy fittings (**Antirust**)

### FINISH OPTIONS

Powder coated steel components or stainless-steel finish.  
Custom colour matching available upon request.



### MODELS

	Size (mm)			Packing Size (mm)	Packing Volume (m <sup>3</sup> )
	W	D	H		
<b>RC-1215</b>	1200	600	1500	1220 x 620 x 1520	1.150