

CORROSIVE STORAGE CABINET

MACHLAB[®] safety cabinets have distinctive features that meet international regulatory and compliance requirements for safe chemical storage and protection.

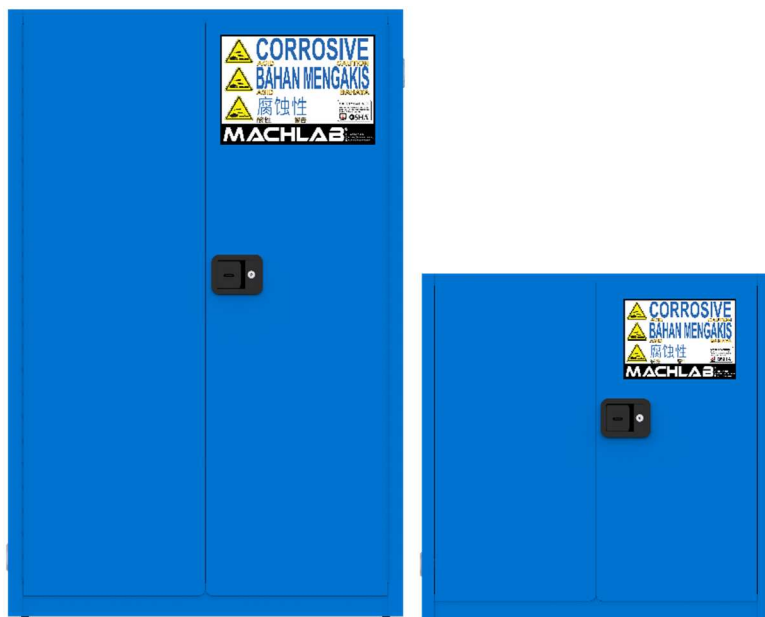

Standard

Under-bench

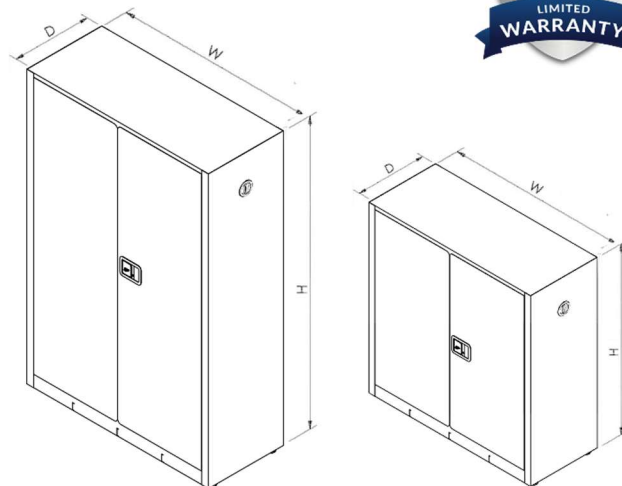

FEATURES

- **High performance design** to meet OSHA and NFPA standards for safe storage of corrosive solvents or chemicals. Includes **PP containment spill trays**.
- **Maximum protection and security** with fail-safe 3-point self-latching lock and full continuous piano hinged doors.
- Constructed of 1.0-1.2mm thick double walled, fully welded steel with 38mm of insulating air space for **fire resistance**.
- **Prominent warning label** in multiple languages.

COMPLIANCE & REGULATORY REQUIREMENTS

- **OSHA** 29 CFR 1910.106.
- **NFPA** Code 30 Section 5.9.3.
- Federal, state, and local regulations may apply.
- Contact your local Fire Marshall for guidance.

MODELS

| | Capacity | | Size (mm) | | | Adjustable Shelves | Packing Size (mm) | Packing Volume (m ³) |
|--------------|----------|--------|-----------|-----|------|--------------------|-------------------|----------------------------------|
| | Gallons | Litres | W | D | H | | | |
| SCC22 | 22 | 83.0 | 889 | 559 | 889 | 1 | 909 x 579 x 909 | 0.478 |
| SCC30 | 30 | 114.0 | 1090 | 450 | 1120 | 1 | 1110 x 470 x 1140 | 0.595 |
| SCC45 | 45 | 170.0 | 1090 | 450 | 1650 | 2 | 1110 x 470 x 1670 | 0.871 |
| SCC60 | 60 | 227.0 | 850 | 850 | 1650 | 2 | 870 x 870 x 1670 | 1.264 |
| SCC90 | 90 | 341.0 | 1090 | 850 | 1650 | 2 | 1110 x 870 x 1670 | 1.613 |